

Micro-Mark®

340 Snyder Avenue, Berkeley Heights, NJ 07922 • Tech Support: 908-464-1094
www.micromark.com MMTechService@micromark.com

OPERATING INSTRUCTIONS FOR #80849 PROFESSIONAL 10" DISK SANDER

MOUNTING THE MACHINE

Carefully unpack the sander. Save the packing materials should you ever need to return the machine to us for any reason.

Place the sander into position on your workbench, but do not plug the power cord into the wall socket. Using the wood screws provided in the parts bag, attach the sander to your workbench...**it is important for your safety that the sander be securely mounted.** For portability, the sander may be mounted to a piece of 3/4" thick plywood using hardware available from your local hardware store. The plywood can then be secured to your workbench with C-clamps.

Loosen the knob on the left side of the machine and reposition the table so that it is at a right angle to the metal disk. Use a square or triangle to position the table properly (figure 1) and tighten the knob. If the angle indicator pointer on the left side of the machine is not pointing to the "0" on the angle scale, it may be reset by loosening the retaining screw, adjusting its position, and then tightening the retaining screw.

INSTALLING THE SANDPAPER

Coarse, medium and fine sandpaper disks are supplied with your sander. Select the one you want to use and peel off half of its backing paper (figure 2). **HINT: a metal ruler may be used as a tear-off bar.** Slide the half of the sandpaper that still has the backing paper attached down behind the table (figure 3) and, with the sandpaper in proper position on the metal disk, apply finger pressure to attach the sticky part of the sandpaper to the metal disk (figure 4).

Rotate the disk until the sandpaper with the backing paper is on top (figure 5). Peel off the remaining backing paper from the sandpaper (figure 6) and again use finger pressure to secure the sandpaper to the metal disk (figure 7). Be sure the sandpaper has been attached to the metal disk without wrinkles.

REMOVING THE SANDPAPER

If the sandpaper disk is difficult to remove, first sand a piece of wood for a few seconds. This will warm the adhesive and make removal easier.

USING THE SANDER

You may now plug in your sander and turn it on.

Rotate the knob located next to the on-off switch to select the speed that is best suited for the material you are sanding: generally, use slower speeds for hard materials and faster speeds for the softer materials. Hold the material you are sanding on the side of the disk that is moving down towards the table (the left side) in order to prevent the material from lifting. Move the material back and forth a little so as to get an even "cut" from the sandpaper. Avoid using too much pressure, otherwise both the material being sanded and the sandpaper itself will overheat. To sand long pieces, remove the safety guard, but be extra careful of your finger location. See figures 8, 9 and 10 for sanding suggestions. Compound miters may be sanded by using a combination of the miter gauge and the tilt table.

MAINTENANCE

No maintenance should be required for your sander other than an occasional cleaning. If the drive belt should ultimately need a tension adjustment, it is located beneath the cover plate below the table. Use the supplied Allen wrench to remove the cover mounting screws and gain access to the motor-mounting/belt-tension adjustment screws.

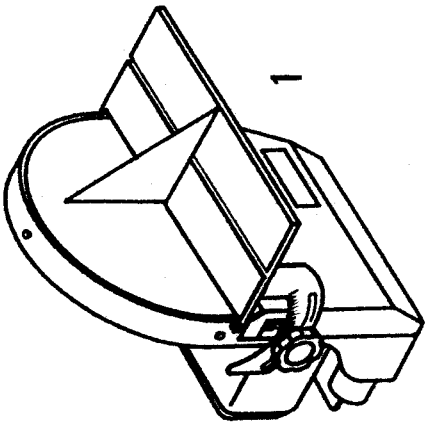

1

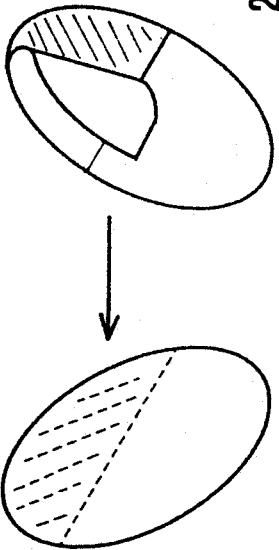

2

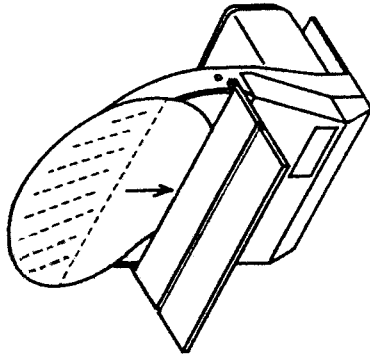

3

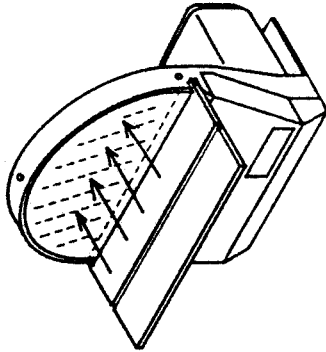

4

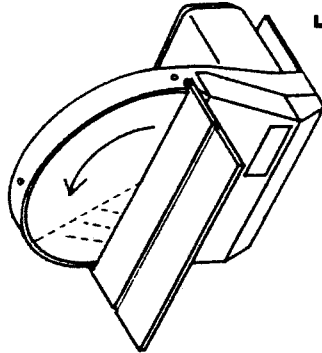

5

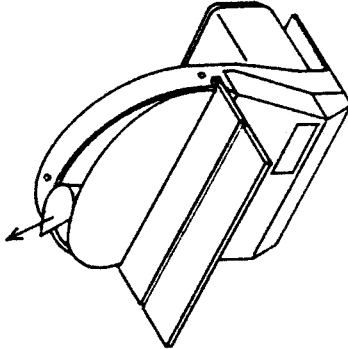

6

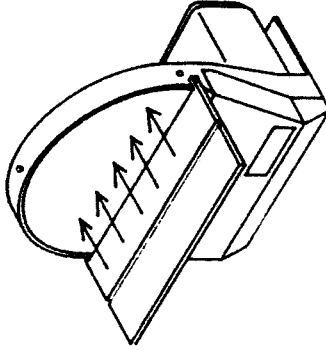

7

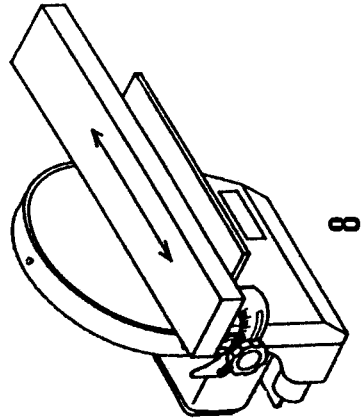

8

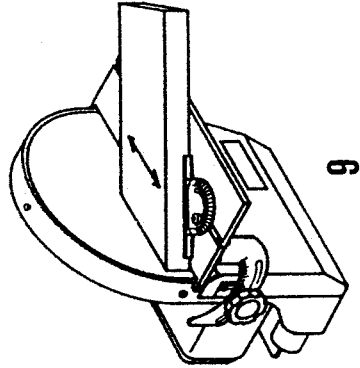

9

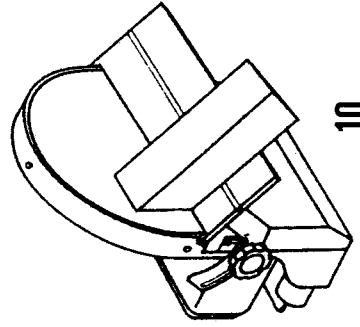

10