

#82812 CAM-LOCKING TAILSTOCK INSTALLATION INSTRUCTIONS

Cam-Locking Tailstocks are individually fitted to MicroLux machines at the factory. Fitting this accessory tailstock to your machine requires the following work to align it perfectly with your headstock:

Set Up for Adjustment

Install the Cam-Locking Tailstock on your lathe bedway. Install an MT3 dead center in cleaned headstock hole (without chuck). Install an MT2 dead center in cleaned cam-lock tailstock hole. Bring the point of tailstock dead center to meet the point of the headstock dead center. If the two points meet perfectly in the middle, then you are finished. If they do not meet, you need to adjust the tailstock.

Horizontal Adjustment

The tailstock is in two sections. Underneath the rear of the tailstock, there are adjustment screws. Loosening the two screws will loosen the top section. Adjust the two sections horizontally until the two dead center points align perfectly in the middle when viewed from directly above. Then tighten the set screw. Remove the tailstock from the lathe, then tighten the bottom screw.

Vertical Adjustment

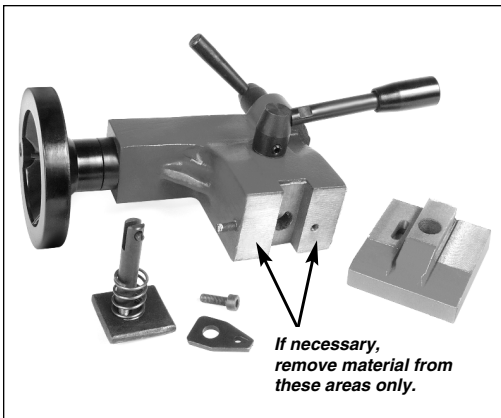

You may also need to adjust the height of the tailstock if the two points of the dead centers fail to meet. If the tailstock is too high, then you need to remove the top section of the tailstock and remove material evenly from the bottom of it a little at a time, using a grinder, file, sander or other tools, until the height matches. If the tailstock is too low, install shims (very fine and thin steel sheets) between the top and bottom sections until the dead center points meet perfectly.

Note: Avoid scraping the section underneath the bottom section of the tailstock (that rests on the bedway). Sometimes, there is some paint or some debris underneath the tailstock. This may require a very gentle cleaning with some wet & dry emery paper (like sand paper), so that it can fit the bed properly. Do not remove material from the bed of the lathe. Any scraping or adjustment should be done only to the area between the top and bottom sections of the tailstock.

Micro-Mark[®] 340 Snyder Avenue
Berkeley Heights, NJ 07922

Tech Support: 908-464-1094

www.micromark.com MMTechService@micromark.com

MM100906