

INSTRUCTIONS FOR #83645 IRDOT-2D and

#83646 IRDOT-2DEW (Extended Wires)

The IRDOT-2D has the same terminal connections as the IRDOT-2. The difference is that the IRDOT-2 operates immediately an object passes over it, the relay and LED switching off immediately as the object leaves. The IRDOT-2D immediately operates its relay and LED upon detecting, but, after the object leaves the infra red beam, there is a 5 second delay before the relay and LED switch off. This delay is useful, because it allows one train to move out of its section before the following train moves up. Also the delay makes the IRDOT-2D ignore the gaps between cars.

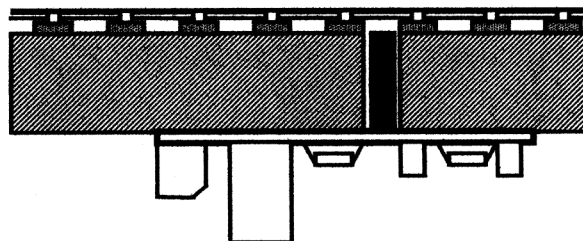

INSTALLATION: The unit is screwed to the underside of the baseboard with the infra red emitter and detector located in a hole between the ties. It is easiest to install the units after the track is laid. Drill a small pilot hole between the ties. Fit an 8mm drill bit marked with tape for slightly less than the base board thickness. Drill from underneath the baseboard following the pilot hole. Cut or file the small amount of baseboard material left between the ties. Install the unit, and then fill the remainder of the hole with modelling material. Blue tack will hold the units in place temporarily. Use 1.2-mm holes for the self-tapping screws that hold the units permanently in place. When fitted to Z or N gauge track, the gap between ties will be less than the diameter of the infra red detector and emitter; however, the modules work well provided they are adjusted to fit close to the ties. This positioning prevents reflections off the sleepers, causing detection. The modules will also operate on their side placed alongside the track. For thick baseboards and restricted space, use units with the emitter and detector fixed to extended leads.

OPERATION: When the IRDOT-2D detects a train, it lights an LED and operates a relay. Terminals 4 and 3 are connected when a train is detected. Terminals 2 and 4 are connected when no train is detected (LED not lit). The IRDOT-2D is supplied with a 5mm diameter red LED connected to the correct screw terminals. This provides an aid while installing the IRDOT-2D to check for reflections off obstructions.

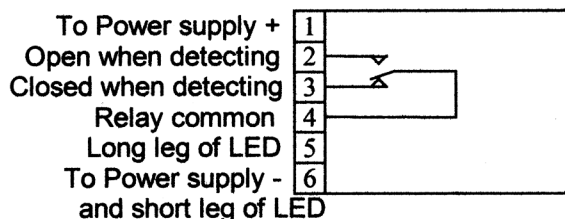

After installation, the LED is wired to the control panel.

Ensure that the long leg is wired to terminal 5. If several IRDOTs are used, all the short legs of the LEDs may be connected together and a single connection taken to one of the terminal 6 connections. The LED will be damaged if it is connected directly to the power supply. It requires a current limiting resistor. This is built into the IRDOT-2D.

POWER SUPPLY

The diagram shows how to connect a number of IRDOTs to the same power supply.

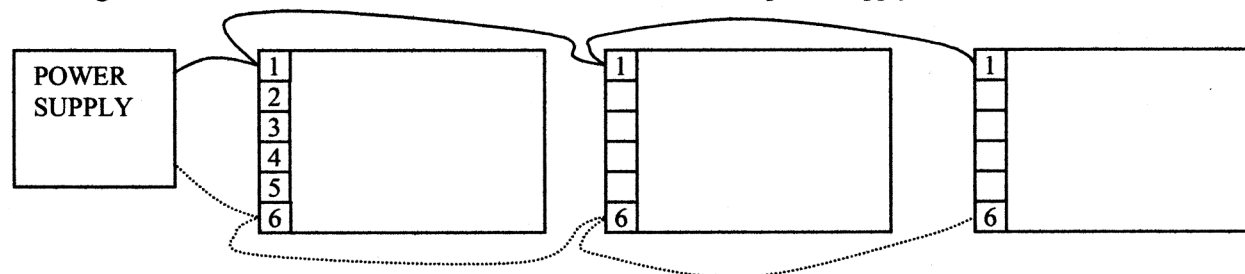

As the current consumption is low, many units can be powered by the same supply. The supply should be from 12 to 16 volts. The units work with either AC or DC. If DC is used, the positive connection of the power should connect to every terminal 1. If AC is used, it is important to be consistent and connect all terminal 1s to the same power supply terminal.

HIDDEN SIDINGS AND LOOPS: The infra red may reflect off low tunnel ceilings causing a permanent detection. The sensitivity of the unit can be lowered in the following ways: Paint the tunnel ceiling matt black to reduce the reflected infrared. Bend apart the infra red emitter and detector. Restrict the amount of infra red transmitted and received by blocking off part of the hole in the rubber covering of the emitter and detector. If any rolling stock is not detected by the units, white self adhesive labels can be stuck to the underside of the rolling stock to increase the infra red reflection.

INCREASING INFRA RED RANGE The rubber heat shrink covering the emitter and detector may be trimmed back to increase the range. Do not expose the infra red detector, as this will allow the infra red to travel straight from emitter to detector, giving false detection.

Automatic storage for a row of trains: IRDOT-2D units can be used to store a queue of trains, automatically moving trains up into empty sections. The IRDOT-2Ds also provide LED indication of the occupied sections.

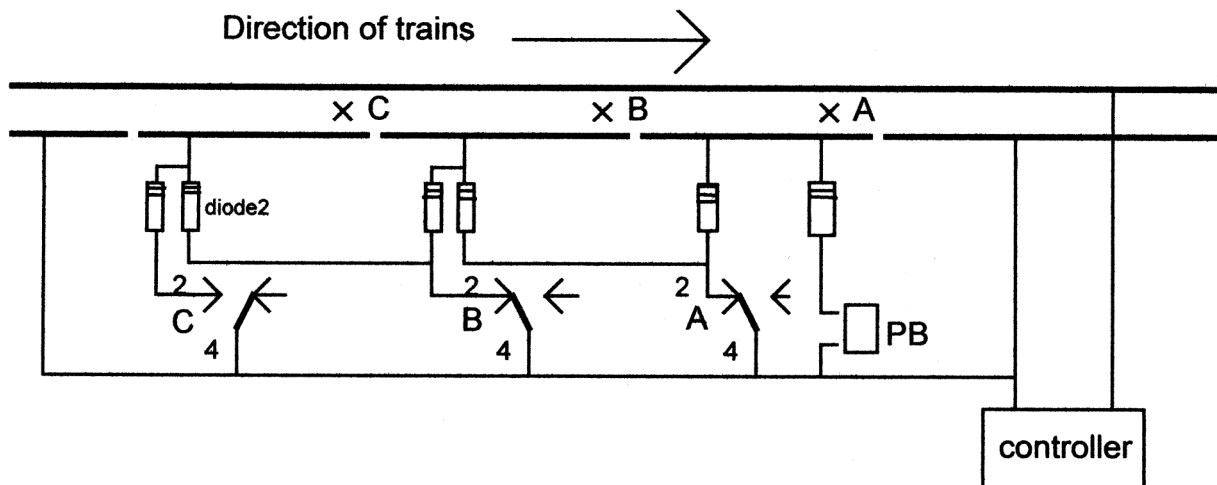

The diagram shows 3 storage sections A, B, and C separated by isolation breaks. Each section has an IRDOT-2D positioned at X (no delay is necessary at C, so either an IRDOT-2 or IRDOT-2D can be used at this position). Electrical connections from the isolated sections are through a diode and the IRDOT-2Ds relay contacts back to the controller. When no train is over the IRDOT-2D, the relay contacts 2 and 4 are connected, powering sections of the track through the diodes. (Relay contacts 2 and 4 refer to the numbering of the terminal blocks of the IRDOT-2D). Further track sections may be added to the left.

Suppose a train moves from the left into section C. Power will be connected onto the track through the relay contacts until the front of the train is detected by the IRDOT-2D. The relay will then open. If there is no train in section B, the track in section C will still be connected to the controller through diode 2 and section B's relay contact. When a train is in section B, the train in section C will be isolated and will stop when it is detected by the IRDOT in section C. When the train leaves section B, the train in section C will move up into the next empty section. A train moving into section A will be isolated and stopped when detected. The push button switch "PB" is used to connect power to the track. The switch should be a "push to make" type.

Diodes

The diodes are used to prevent unwanted connections between sections. They are one-way valves for electricity, with the band indicating which way the electricity can flow (our diodes are black with a silver band at one end). Looking in the direction a train is travelling, the right hand rail will be positive and the left hand rail negative. Hence, for the electricity (current) to flow back to the controller so that the train can move, the band needs to be towards the positive rail as shown in the diagram. If the isolation breaks are in the negative rail, the diode band would need to be away from the rail. Note that feedback controllers will not work with diodes, because the diode prevents the feedback signal reaching the controller. If feedback controllers are used, 2 pole relays can be used in place of the diodes.

Controller/train speeds

The train may overshoot the detector if it is running at a fast speed. If this is a problem, it may be best to use a separate controller set to a low speed which only powers the storage sidings.

HEATHCOTE ELECTRONICS, 1 HAYDOCK CLOSE, CHEADLE, STAFFS, ST10 1UE
 TEL/FAX 01538 756800 email heathcote.electronics@btinternet.com
 web site www.heathcote-electronics.co.uk

Distributed by Micro-Mark, 340 Snyder Avenue, Berkeley Heights, NJ 07922
www.micromark.com