

**OWNER'S MANUAL  
ASSEMBLY – OPERATION – SAFETY**

**FOLDABLE TOPSIDE CREEPER**

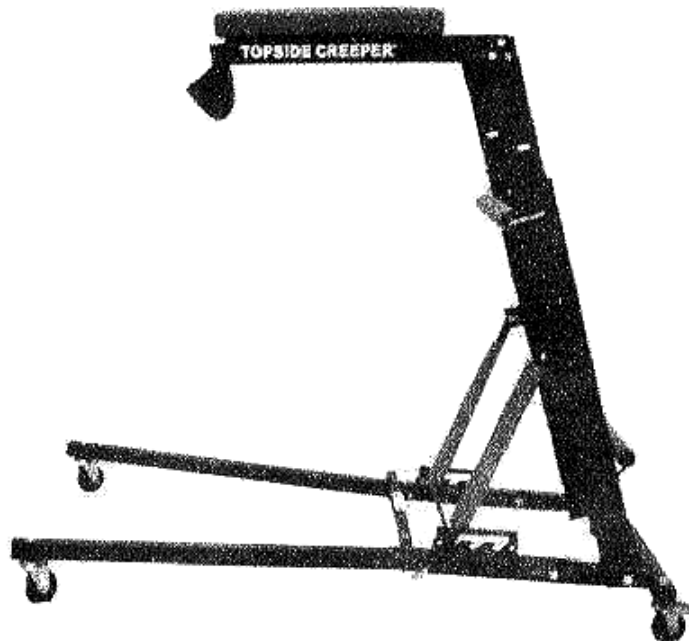

**IMPORTANT:** Read, understand and follow ALL Safety Rules and Operating Instructions before using this product.

## **SAFETY FIRST**

**WARNING** : Failure to follow these safety requirements could result in personal injury.

- This product is a tool to reach what are normally hard to reach places, such as the topside of engine compartments for mechanics and can also be used to reach equally hard to reach places such as far reaching areas on a train set for the hobbyist.
- Always inspect the product for damage before each use. Do not use if damage is evident.
- Make sure all nuts and bolts are secure before each use.
- Always engage the casters' locking mechanism before climbing.
- Always make sure both spring loaded height adjustment pins are fully inserted through step section side rails before climbing the Topside Creeper.
- Always be sure the angle adjustment bar is secure in one of the three position slots before using.
- Always face the Topside Creeper when climbing up or down. Use both hands and keep your body centered between side rails.

## **DO NOT USE THIS PRODUCT IF**

1. You tire easily or are subject to fainting spells.
2. You are taking medications that could impair judgment.
3. You are under the influence of alcohol.
4. You are physically challenged.

## **DO NOT**

**SIT OR STAND ON THE CHEST PAD**

**OVERLOAD THE PRODUCT ... THE MAXIMUM LOAD CAPACITY IS 400 LBS  
WHICH INCLUDES BODY WEIGHT, TOOLS  
AND TORQUE APPLIED TO TOOLS.**

**DO NOT USE THE TOPSIDE CREEPER OVER A RUNNING ENGINE.**

## OPERATING INSTRUCTIONS

### **A. USING THE ADJUSTABLE ANGLE LEAN-IN FEATURE**

There are three different lean-in angles that can be achieved to better enable the user to accomplish each particular task safely and efficiently.

#### **TO ADJUST ANGLE LEAN-IN :**

1. Lock casters (A2) by pressing on the locking tab with foot.
2. Push back on step section (O)
3. Move angle adjustment to one of the three notches located on the base.

### **B. CHANGING THE WORKING HEIGHT**

The working height of the Topside Creeper can be adjusted to fit the needs of each individual task from 44" up to 68" in height.

#### **TO CHANGE WORKING HEIGHT**

1. Lock casters (A2) by pressing on the locking tab with foot.
2. Grasp a step within the sliding section with one hand while using the other hand to pull one of the spring loaded locking pins outward, removing it from it's locked position.
3. Repeat step # 2 to remove the second pin. **IMPORTANT : One hand MUST have a firm hold of a step within the sliding section when the second spring loaded locking pin is removed from the locked position. This prevents the sliding section from free falling which could cause personal injury.**
4. Slide the inside step section up or down to desired height, always maintaining a firm grip.
5. While holding a step within the sliding section with one hand guide one of the spring loaded locking pins into it's corresponding hole in outside rail.
6. While maintaining a firm hold of sliding section move it up or down until the spring loaded locking pin releases through one of the oval shaped height adjustment holes located in the side rails of the sliding section.
7. Guide and insert the second spring loaded locking pin through both the outside rail and oval shaped hole of the inside sliding section rail.

## **OPERATING INSTRUCTIONS (CONTINUED)**

### **C. FOLDING THE BASE SECTION**

The TOPSIDE CREEPER model # 1-00020 features a folding base section to allow for convenient, less space consuming storage.

#### **TO FOLD THE BASE SECTION**

1. Lock Casters (A2) by pressing downward on locking tab with foot.
2. Remove two pins (I) from assembled base section (K), (M1) & (M2).
3. Grasp and raise one of the two legs (M1) or (M2) until they rest against the climbing section.
4. Replace pins (I) back into their original holes for safekeeping.
5. Reverse this procedure to return the unit to working position.

**NOTE : WHEN MANEUVERING THE TOPSIDE CREEPER IN THE FOLDED POSITION ONLY A SLIGHT "TILT" IS NECESSARY. THE MORE THE UNIT IS TILTED THE MORE DIFFICULT IT BECOMES TO MANEUVER. IT IS ALSO EASIER TO PULL THE FOLDED UNIT AS OPPOSED TO PUSHING IT WHEN IN THE FOLDED POSITION.**

# Parts and Hardware

**A1 - Front Caster x 2**



**A2 - Locking caster x 2**



**B - 12mm Flange Nut x 4**



**C - 12mm Lock Nut x 4**



**D - 8mm Lock Nut x 8**



**E - 6mm Lock Nut x 6**



**F - 2.5" x 12mm  
Bolt x 4**



**G1 - 3" x 8mm  
Bolt x 2**



**G2 - 9/16" x 8mm Bolt  
x 6**



**G3 - 1/2" x 6mm Bolt x 4**



**H - 5/8" x 6mm Phillips  
Screw x 4**



**I - PIN**

**x 2**



**J - Square Tube**



**M1 - Right Leg**



**M2 - Left Leg**



**K - Base**



**O - Step Section**



**N  
Angle Adjustment  
Keeper x 2**



**L - Chest Pad Frame**



**P - Chest Pad**



**S - Pouch Bracket**



**R - Pouch**



**U - Bumper Pad x 3**



**Q - Washer x 2**



## ASSEMBLY INSTRUCTIONS

Tools Needed : 12mm wrench, 8mm socket  
6mm wrench, philips screwdriver

## BASE ASSEMBLY

Assemble legs (M1 & M2) to Base (N) using Bolts (F), Nuts (C) and Pins (I) as shown. Do not overtighten.  
**NOTE:** The two legs must be angled outward with angle adjustment notches positioned to the inside.

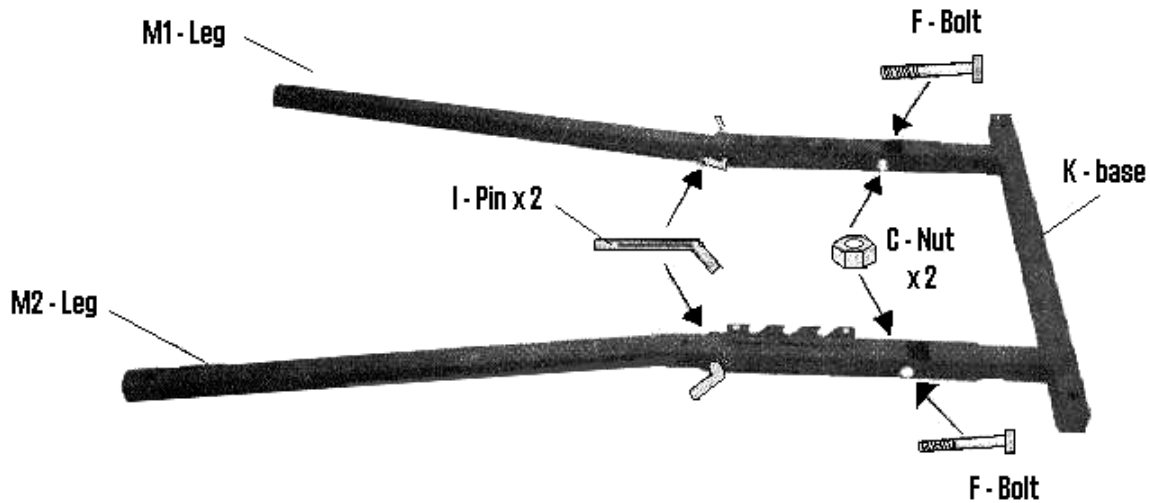

## CASTER ATTACHMENT

With angle adjustment notches upward, secure two Locking Casters (A2) to closed end of base (N) using Flange Nuts (B). Secure two non-locking casters (A1) to the outward protruding legs using Flange Nuts (B) as shown.

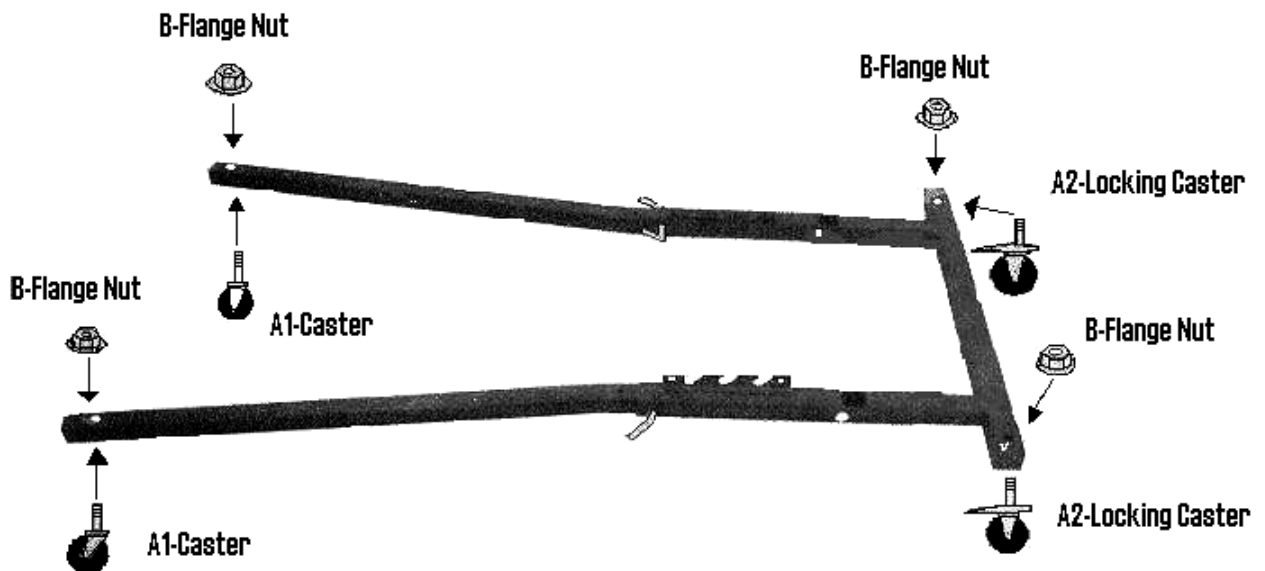

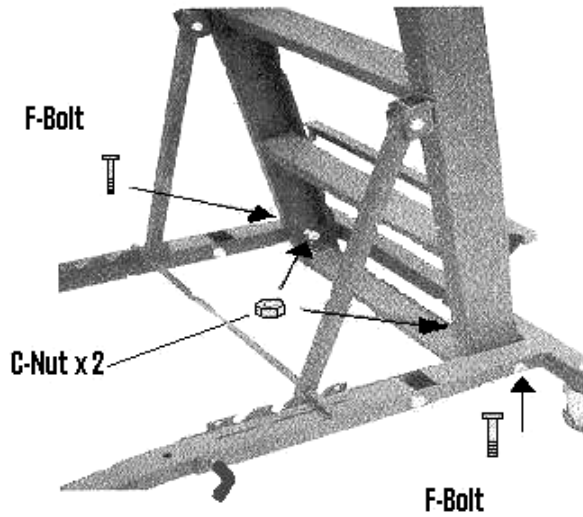

## SECURE CLIMBING SECTION TO BASE SECTION

**IMPORTANT:** Inside step section must be secured before proceeding. Insert both spring loaded adjustment pins into corresponding hole in outside rail of Climbing Section (M). Slide inside step section frame until both spring loaded adjustment pins fully engage through oblong adjustment holes of inside rails.

Position step section (O) as shown. Secure step section to base using two Bolts (F) and two Locknuts (C).

## SECURE ANGLE ADJUSTMENT KEEPERS

Place angle adjustment bar into one of the three adjustment slots located on the base. Secure Angle Adjustment Keepers (N) to base using Bolts (G3) and Lock Nuts (E).

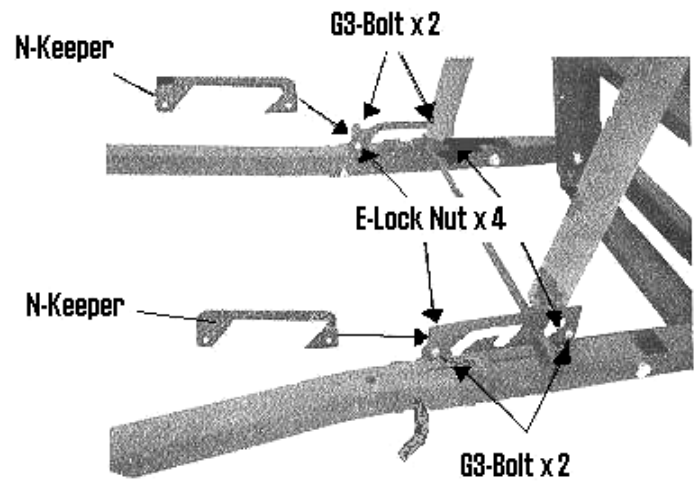

## ATTACH BASE CROSS BAR SUPPORT

Using two Bolts (G1), two Nuts (D) & washers (Q) attach Square Tube cross bar support (J) to base as shown.

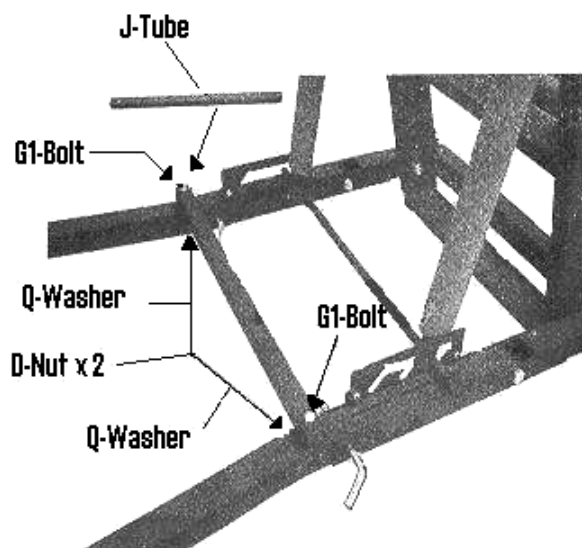

---

## ATTACH CHEST PAD FRAME

Using Bolts (G2) and Nuts (D) secure chest frame to climbing section as shown.

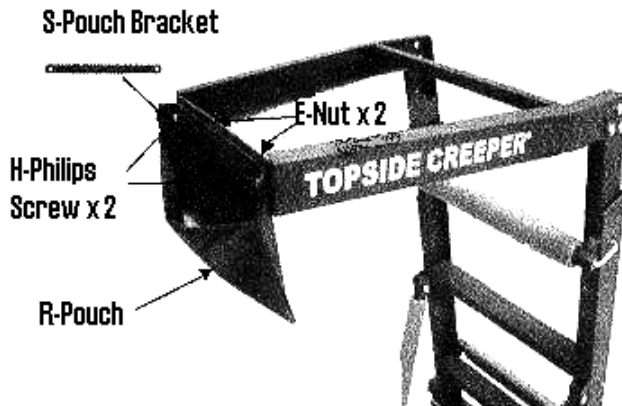
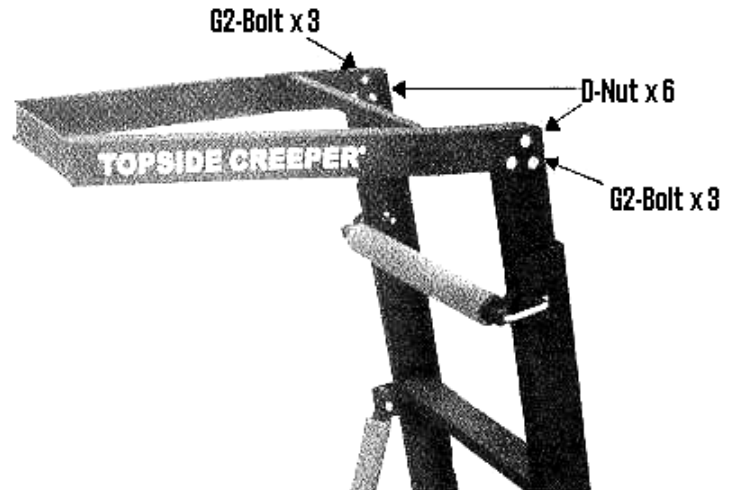

---

## ATTACH TOOL POUCH

Insert Philips Head Screws (H) through Bracket (S), Pouch (R) and Chest Pad Frame as shown. Secure to frame using lock Nuts (E).

---

## ATTACH CHEST PAD

Using two philips head bolts (H) secure chest pad to chest pad frame by inserting through holes in bottom of frame and into threaded inserts in bottom of pad.

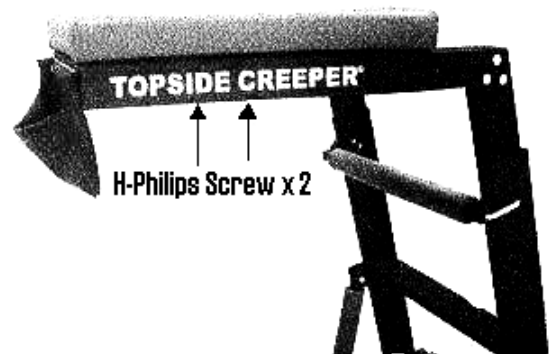

**ATTACH BUMPER PADS** To angle adjustment bars and adjustment pin cross bar as shown

