

INSTRUCTIONS FOR #83914 ARC WELDER with SOUND EFFECTS

The welding effects board has a “hot glowing metal effect” red LED and a welding-effect blue LED.

LEDs

The short legs of the two LEDs connect to the 0V terminal. Connect the long leg of the red LED to terminal A. The red LED gradually increases its brightness during welding (blue LED lit) and diminishes its brightness when the welder is off.

There is a choice of terminal B or C for the blue LED: Connecting the long leg of the blue LED to terminal B switches the blue LED on and off. Connecting to “C” gives the same effect with a superimposed “electrical” flicker. The blue welding LED lights for random amounts of time. The average lit/unlit times can be increased or decreased by rotating the “pot” with a small screwdriver. The LEDs do not have built-in resistors.

Power Supply

The unit is powered from 12 to 16 volts either AC or DC wired as shown in the diagram.

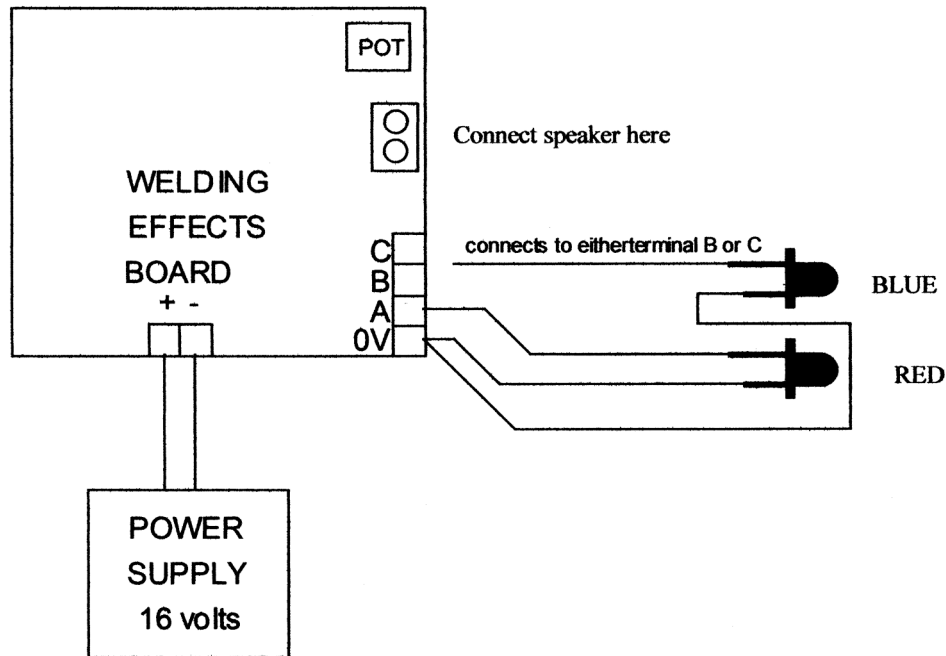

HEATHCOTE ELECTRONICS, 1 HAYDOCK CLOSE, CHEADLE, STAFFS, ST10 1UE TEL/FAX 01538 756800
email heathcote.electronics@btinternet.com
web site www.heathcote-electronics.co.uk

Distributed by Micro-Mark, 340 Snyder Avenue, Berkeley Heights, NJ 07922

www.micromark.com
MM062907