

INSTRUCTIONS FOR #84040 SIMPLE SHUTTLE

The SIMPLE-SHUTTLE is for use where the train is to run slowly so acceleration and braking are not required (see SA1 if you require acceleration braking and adjustable waiting). It consists of an infra red train detection circuit, an electronic circuit to provide control of the direction and stopping of the train and an adjustable timer to control the length of time the train is stopped before changing direction. Also required are; one IRDOT1 or 1 reed switch to provide detection at the other end of the line, a controller (unit will work with both feedback and non feedback types) to provide power to the track, and a 12-16volts supply either AC or DC.

POSITIONING THE SIMPLE SHUTTLE AND IRDOT-1

As soon as the infra red detects the train power will be switched off. Each unit will therefore need to be positioned where the leading end of the train is to stop. The leading edge of the train may move a little past the detector due to inertia or effects of flywheels.

INSTALLATION

Drill a small pilot hole between the sleepers where the infra red detectors are to be fitted. Drill an 8mm hole from beneath the baseboard using the pilot hole as a guide. (Mark the 8mm drill bit with tape so that the depth of the hole is slightly less than the thickness of the baseboard.) File or cut away the small amount of baseboard remaining between the sleepers. Provided the infra red emitter and detector are very close or touching the sleepers the unit will work with the sleepers over the edges of the infra red devices. Gaps between the hole and infra red devices can be filled with modelling materials after the wiring has been tested. The unit works with the normal sleeper spacing of Z gauge and all larger gauges.

CONNECTION TO POWER SUPPLY

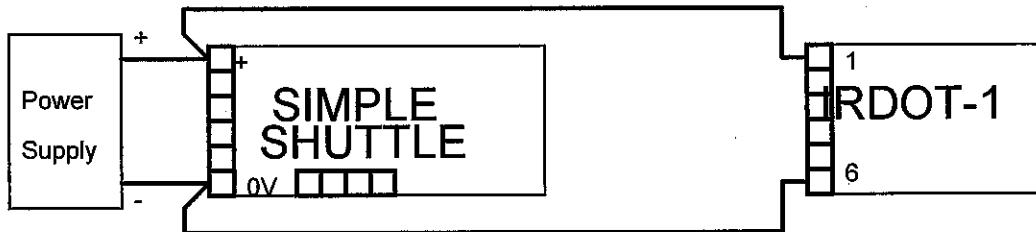

The SIMPLE SHUTTLE and IRDOT-1 can be powered from 12 to 16 volts either AC or DC. If using DC the positive side of the power supply is connected to the + terminal of the simple shuttle and terminal 1 of the IRDOT-1.

If using an AC power source be careful to connect the + terminal and terminal 1 to one terminal of the power source and the 0V terminal and terminal 6 to the other. "crossing over" the connections will result in each unit working individually but interconnections failing to work.

After wiring check the units are detecting trains correctly by running rolling stock over them. As the rolling stock passes over the units the train detected LED should light. (see later for details) With no rolling stock over the units the LED should not light. If the LED is permanently lit check it operates correctly when the unit is removed from the baseboard. The cause of the problem will be found to be either reflection from sleepers (solved by slight repositioning of the Shuttle or IRDOT-1 or moving it closer to the sleepers) or reflection from overhead bridge or tunnel ceilings. Solved by painting matt black or fixing a piece of foam or felt (which are very poor infra red reflectors) to the tunnel ceiling.

INTERCONNECTION BETWEEN UNITS

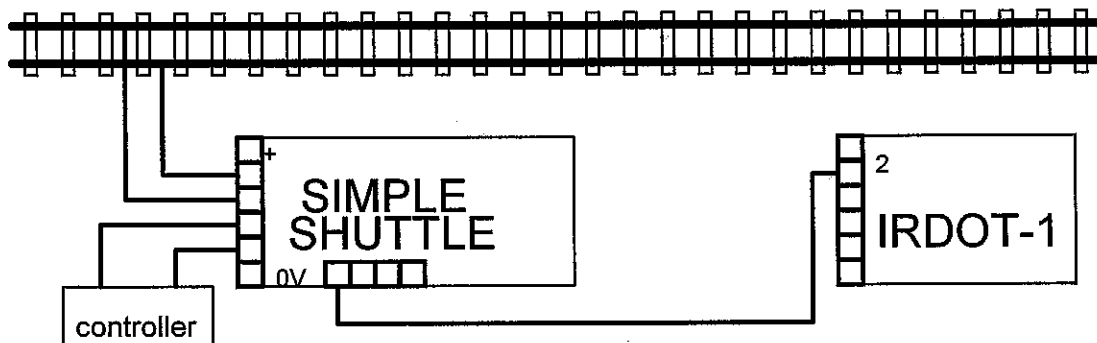

A wire is connected from terminal 2 of the IRDOT-1 to terminal A of the SIMPLE SHUTTLE. This wire tells the SIMPLE SHUTTLE when the train has arrived at the IRDOT-1 end of the track. The controller and track connections are also shown on the diagram. With no power connected to the SIMPLE SHUTTLE the controller should power the train.

TRAIN DETECTION LED

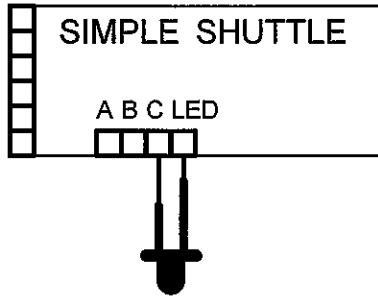

The simple shuttle is fitted with a train detection LED. The long leg of the LED goes to the "LED" terminal and the short leg to the "C" terminal. This LED may be wired to the control panel.

In addition to showing train detection the LED also indicates the length of time the train stops for by flashing more quickly for short pauses than for long ones. The stopping time is adjusted by rotating the "pot" (mounted on the board) with a small screwdriver.

OPERATION

Switch on the power supply. Turn on controller with engine moving towards the SIMPLE-SHUTTLE. When the train reaches the SIMPLE-SHUTTLE it should stop for the adjustable delay. The red LED on the simple shuttle should flash during this pause. After the pause the train returns towards the IRDOT-1 end of the track. When detected by the IRDOT-1 another adjustable delay occurs then the train restarts moving towards the SIMPLE-SHUTTLE.

SIDINGS

By having one or more sidings, two or more trains can run alternately along the line. The sidings are located at the other end of the line to the SIMPLE-SHUTTLE. At the end of every siding an IRDOT-P is used. The IRDOT-P does two jobs. Its "R" terminals are wired so that an arriving train causes the points to change to the next siding. Secondly every IRDOT-Ps "P" terminal is wired to the "RR" terminal of the SIMPLE-SHUTTLE so the SIMPLE-SHUTTLE knows when a train has arrived at the siding.

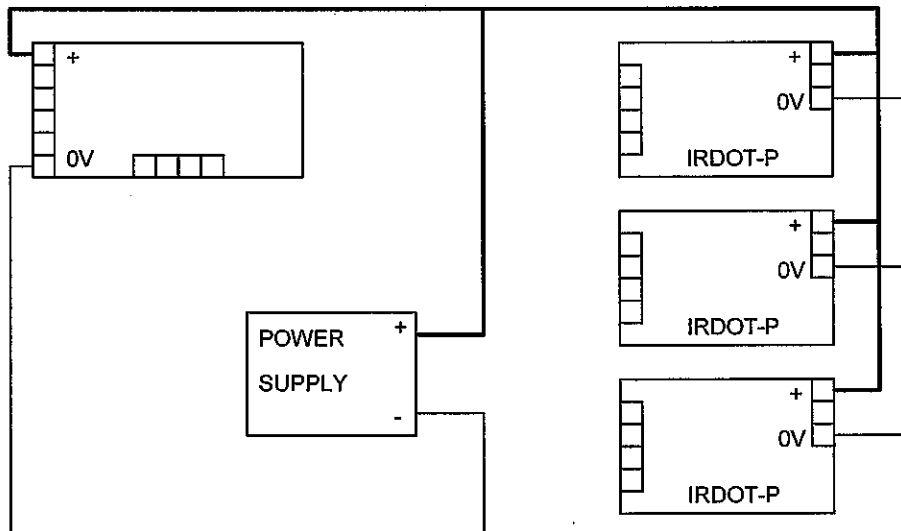
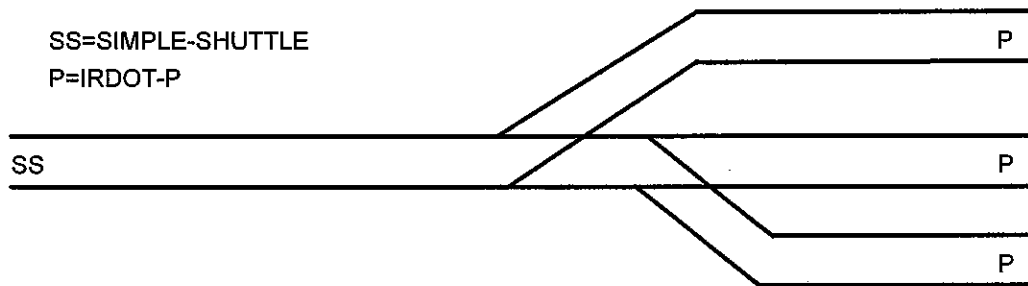
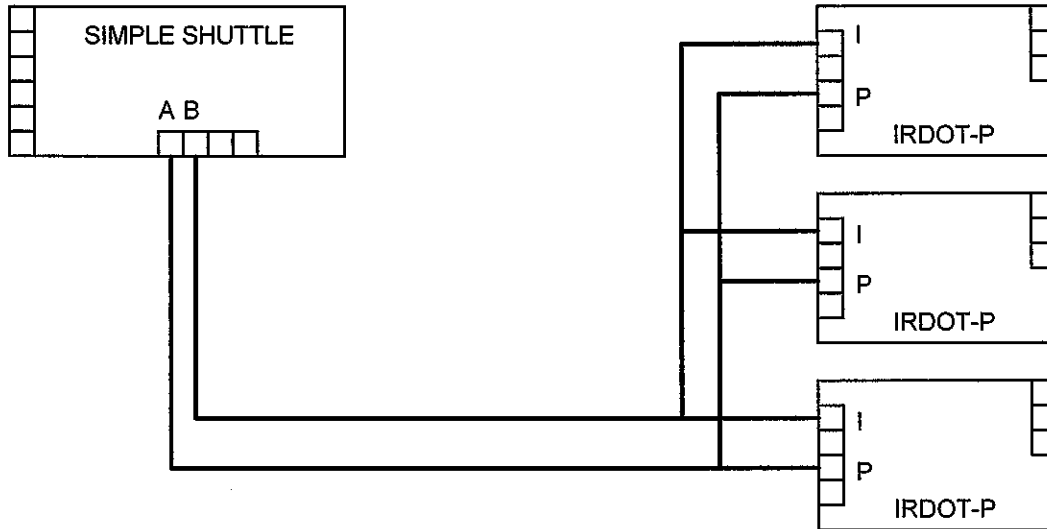

Diagram below shows wiring to power all boards, ie all "+" connections join together

Diagram below shows how "P" terminal is linked into Simple Shuttle to "tell it" a train has arrived and how Simple Shuttle is wired to "I" terminals to prevent points being falsely triggered as a train departs.



MANUAL OVERRIDE

The simplest way to have a manual override is to fit an on off switch into the "+" wire from the power supply. With power to the units switched off the controller will operate the trains in the normal way.

Timing

Timing is adjusted by rotating the "pot" on the simple shuttle board with a small screwdriver. Timing can be adjusted between 10 and 120 seconds

ADJUSTABLE TIME SIMPLE SHUTTLE... FOR TWO TRAINS ALTERNATING BETWEEN TWO STUBS

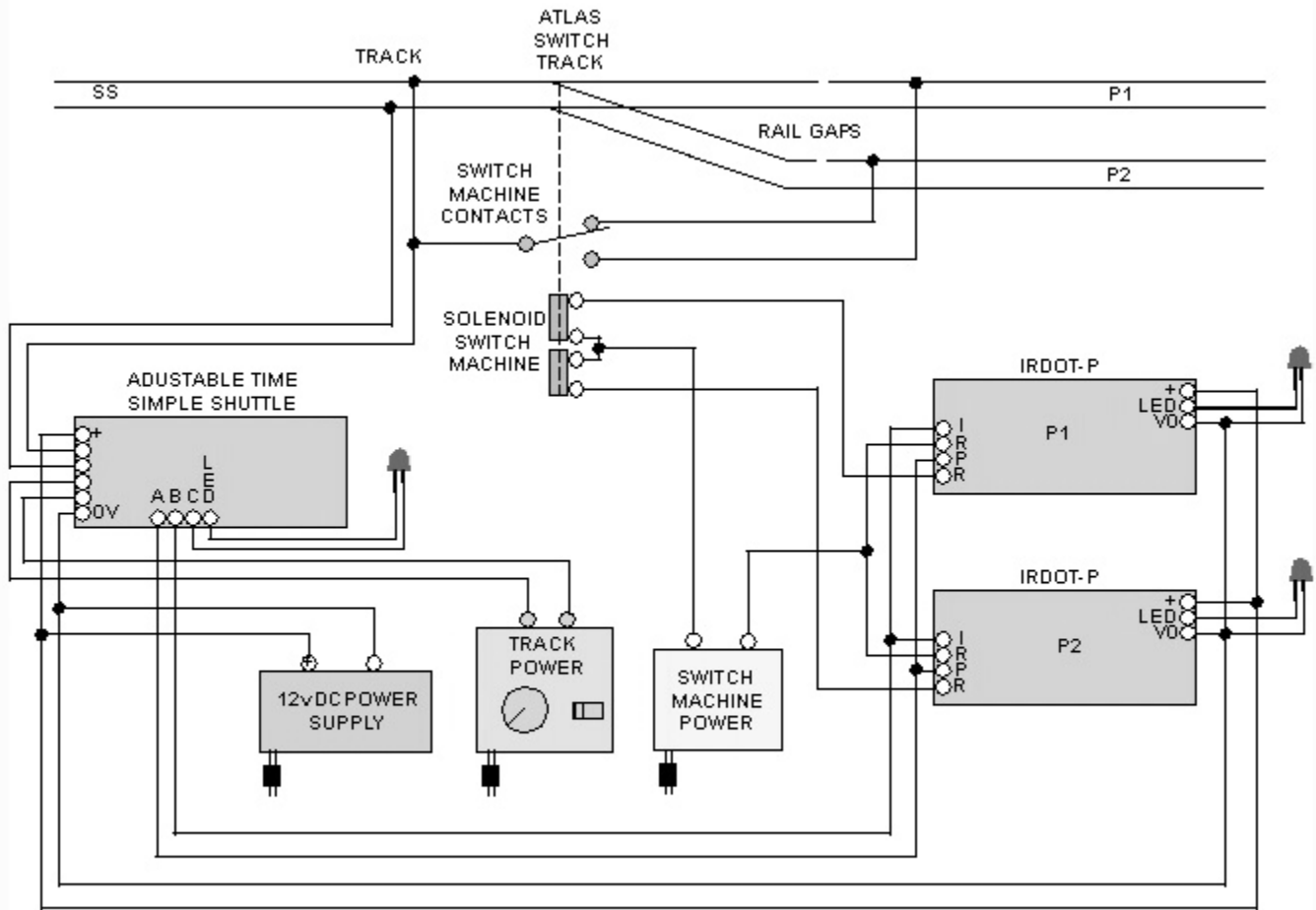

TP 824.07

Micro-Mark®

THE SMALL TOOL SPECIALISTS

340 Snyder Avenue, Berkeley Heights, NJ 07922
 Tech Support: 908-464-1094, weekdays, 1pm to 5pm ET
www.micromark.com MMTechService@micromark.com