



S Gauge DC/DCC Diesel Sound Decoder with Four Prime Mover sounds

Item #0001822

Thank you for purchasing our most advanced DC/DCC locomotive sound decoder. Combined with any DCC System or MRC Blackbox, our true live capture digital sound decoder will make your model railroad come to life.

- Four types of synchronized diesel prime mover sounds:
Alco /SD60/SD70/F
- 3 amp capacity
- 34 different types of horns and 8 types of bells
- Programmable individual sound volumes
- Programmable either 2-digit or 4-digit addresses
- Programmable start voltage and top voltage
- Programmable acceleration and deceleration rates
- Programmable 14, 28, 128 speed steps
- Back EMF load control
- Supports read back address and CV value
- Selectable factory default speed curve
- Advanced speed table control CV67-CV94
- Kick start voltage control CV65
- Easy function mapping
- 3 headlight effects: Directional / rule 17 /off-dim-bright cycle.
- 7 accessory light effects: ditch lights, mars light, gyra light, strobe light, prime strobe light and on/off
- 28 accessory functions (F1-F28)
- Supports advanced consisting (CV19)
- Supports programming on the main (OPS mode)
- Compatible with NMRA DCC standards
- Complies with Part 15 of FCC Rules
- 28 mm speaker included
- Dimensions: 60.0mm x 17.8mm x 5.0mm

INSTALLATION

It is quite a challenge to install the decoder in your loco. You should have some basic electrical knowledge. If you do not have, please ask the dealer for help in installation.

Figure 1 shows the electrical circuit of most standard locos. The terminals of the motor and lights are directly connected to the wheel pickup. Each type of loco has its own method of electrical pickup and distribution. There is no standard rule for installing decoders. It is always better to consult the loco manufacturer on how to install a decoder in your particular loco. First, figure out your loco's electrical wiring and how to disconnect (isolate) the motor and light(s). Label all wires before you disconnect them.

Figure 1. Connection of standard locomotive. *Note: The 'X' marks indicate where to disconnect (isolate).*

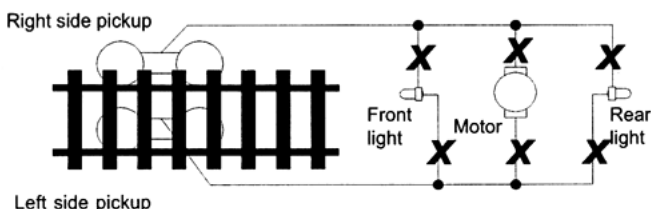
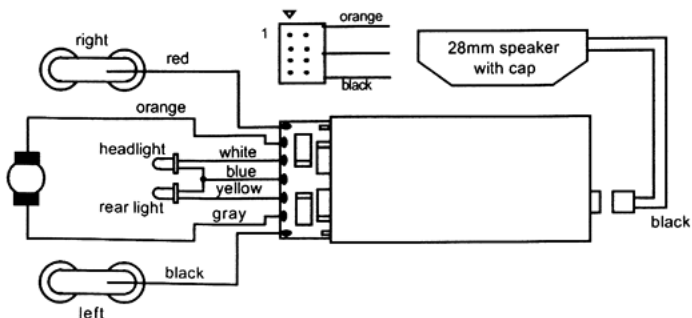

Figure 2. How to wire the decoder.

The decoder will be inserted between the wheel pickup and the motor. After disconnecting the motor terminals from the pickup, connect the right side pickup wires to the red decoder wire, and connect the left side pickup wires to the black decoder wire. Connect the right motor terminal to the orange decoder wire, and connect the left motor terminal to the grey decoder wire. The white decoder wire is for the front headlight, the yellow decoder wire is for the rear headlight, and the blue decoder wire is the headlight common. If you wish to add accessory lights to your locomotive, there are 4 solder tabs on the bottom of the decoder, (flat side), marked; acy 1, com, com, and acy 2. Solder wire to these tabs and make sure that there are no stray wires bridging the tabs. Refer to the CV and Function charts as to programming and operating the accessory lights. If you have enough room inside the locomotive a speaker enclosure can be built around the speaker to improve overall sound quality.

If you have a 1.5V bulb or LED, you should connect a 2k ohm resistor in series to one of the leads to limit current.



MAKING A TEST TRACK

We strongly recommend building a test track with a 27 ohm resistor to limit current. Only test your installed decoder on the test track. The test track will reduce the chance of damaging your decoder due to an incorrectly installed decoder.

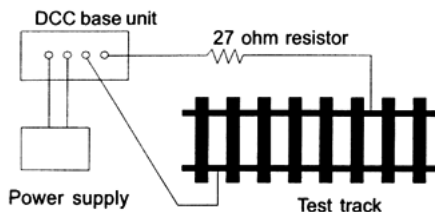

Figure 3. Diagram of test track

TESTING

The decoder has been programmed to address #3, 28/128 speed steps. To test, place the loco on the test track. Select address #3 and 28 speed step. Move up the throttle and the loco should move. Push the light button [F0] and headlight should come on. Change the direction of the loco and the loco should change direction. The loco cannot reach full speed, due to the resistor. If all the above occurs, you passed the test. Congratulations! Do not run the loco for an extended period of time on the test track or the resistor will overheat. If your installed decoder does not pass the test, find the problem, correct it and test it again. As long as you test the decoder on the test track there is little chance of damaging the decoder. This is why the test track is so important.

OPERATION

The decoder has start up and shut down features. If the loco was previously shut down you have to start up the engine. Press any function key to start up the engine before operating the loco. To shut down the engine you must bring the loco to idle and then press F8 three times.

Double click F0 will turn on/off sound (CV49). You can't turn off horn which is always on. The decoder has four types of diesel prime movers. You can use F1: or CV 123 to select the desired prime mover sound or turn them off. If you want the decoder to be used in an Electric Type Traction Loco such as Trolley or GG-set CV 123=4 to turn off the diesel sound. With the prime mover sounds shut off CV 123=4, the traction air compressor will cycle on and off randomly, of course you can still use F11 to activate the compressor whenever you want while in the random mode. You can use F19 to select 34 different horn sounds and use F18 to select 8 different bell sounds. With MRC Prodigy Advance² DCC which has 28 functions, you can easily setup and access all the decoder's functions. If not, you may not be able to access all the features of the decoder. And you have to use the CV program to setup the decoder.

This decoder allows certain functions to be re-mapped easily, (CV numbers- 37 39 and 42). If the values of these CV's are set to "0" (default), normal DCC keypad/functions are applicable. Insetting the values shown in the CV chart allows certain function swapping for example: F3 becomes F4 and vice versa.

The decoder default is set to automatic notch. You can program CV122 to 3 for manual notch for realistic operation. And then use F9 to notch up and use F8 to notch down.

The decoder can also be operated by a regular DC power pack. This will give you synchronized engine sounds only. If you wish to enjoy the full array of sound functions using your DC power pack, the unique MRC Blackbox (item #0001050) for DC operation will allow you to control all of the sounds in your sound equipped locomotives. And, the MRC Blackbox is easy to setup and use.

Function	Idle/Moving
F0	Headlight on/off or rule 17 or cycle of dim, bright, off
Double F0	Double click F0 within 1 second will turn on/off sound (CV49) with Horn on
F1	Bell on/off
F2	Horn
F3	Ditch lights on/off or Acc1 light on/off with air release
F4	Coupling 1
F5	Brake release (idle) / brake squeal (moving)
F6	Dynamic brake on/off
F7	Air hose firing/uncoupling lever
F8	Click 3 times during idle will shut down / notch down while CV122=3
F9	Engine cooling fan / notch up while CV122=3
F10	Rail wheel clack (only moving)
F11	Traction air compressor on/off
F12	Change prime mover type and prime mover off
F13	Acc2 light on/off with air release
F14	Coupler lift bar
F15	Air pump
F16	Associated loco sound
F17	Flange noise 1
F18	Change bell type (use F1 to turn off bell after adjustment)
F19	Horn type select (total 34 different horns)
F20	Associated loco sound
F21	Change bell volume (use F1 to turn off bell after adjustment)
F22	Change horn volume
F23	Change diesel rumble volume
F24	Air release
F25	Flange noise 2
F26	Flange noise 3
F27	Sand drop
F28	Ditch lights steady on/off (CV121) with Air release, use F3 to turn on/off

Note: Bell, Dynamic Brake, and Rail Wheel Clack cannot play at the same time.

LIGHT EFFECT PROGRAMMING CHART FOR CV#118/119

Program CV117 to choose 3 different modes of headlight effects (0=normal directional, 1=off/dim/bright cycle, 2=rule 17). Both ACC1 and ACC2 has 7 different accessory lights effects. Program CV #118/119 to choose the desired light effect. CV118 for ACC1 and CV119 for ACC2. For ditch light both CV118 and CV119 must be 0. In ditch light mode, use F3 to turn on/off and use F28 to enable/disable flash. When you blow the horn the ditch lights will flash. The ditch lights will remain flashing for several seconds after horn is off.

CV118/119 value	ACC#1/ACC#2 Light effect
0	Ditch light
1	Gyra light
2	Marslight
3	Prime strato light
4	Single strobe light
5	Double strobe light
6	on/off

PROGRAMMING

This decoder supports all program modes and read back features. With MRC Prodigy Advance DCC you can read its address and CV value.

CV	Register	Description	Range	Default
CV1	R1	Short address	1-127	3
CV2	R2	Start voltage	0-32	12
CV3	R3	Acceleration	0-32	0
CV4	R4	Deceleration	0-32	0
CV5	---	Top voltage	0-32	32
CV6		Speed curve select (0=linear, 1=slow increase, 2=fast increase at slow speed)	0-2	0
---	R6	Page number	---	---
CV29	R5	Basic configuration	---	2
CV7	R7	Manufacturer version number	22	22
CV8	R8	Manufacturer ID	---	143
CV17	---	Long address upper byte	192-231	192
CV18	---	Long address lower byte	0-255	3
CV19	---	Advanced consist address	0-127	0
CV21	---	When CV21=0, functions follow its own address. CV21=1, functions follow the consist address	---	0
CV37		0=normal, 1=F3 and F4 exchange	0-1	0
CV39		0=normal, 1=F5 and F6 exchange	0-1	0
CV42		0=normal, 1=F8 and F12 exchange	0-1	0
CV49		All sounds on/off except horn that is always on	0-1	1
CV50	---	Horn type (34 types)	0-33	17
CV51	---	Horn volume	0-3	3
CV52	---	Bell type (8 types)	0-7	2
CV53	---	Bell volume	0-3	3
CV54	---	Bell ring rate	0-50	3
CV55	---	Diesel rumble volume	0-3	3
CV56	---	Brake squeal volume	0-3	3
CV57	---	Dynamic brake volume	0-3	3
CV58	---	Air release volume	0-3	3
CV59	---	Air pump volume	0-3	3
CV60	---	Safety pop valve volume	0-3	3
CV61	---	Engine cooling fan volume	0-3	3
CV62	---	Coupling volume	0-3	3
CV63	---	Auto ditch lights flash with horn enable	0-1	1(enable)
CV64	---	Rail wheel clack	0-3	3
CV65		Kick start voltage	0-63	63
CV67-94		28 speed steps table while CV29.4=1	1-255	linear
CV113	---	Coupling fire volume	0-3	3
CV114	---	Brake release volume	0-3	0
CV115	---	Auto brake squeal enable/disable	0-1	1(enable)
CV117		Light mode, 0=normal headlight 1=off, dim, bright cycle, 2=rule 17	0-2	0
CV120		Ultra slow enable	0	0
CV121		Ditch lights flash (=1) or stay on (=0), C118=CV119=0	0-1	0
CV122	---	Notch mode, 0=auto, 3=manual	0-3	0
CV123		Prime mover: 0=SD60, 1=F, 2=Alco, 3=SD70, 4=off, with traction air compressor cycling randomly	0-4 (4=off)	3(SD70)
CV124		Back emf load control on/off	0-1	0(off)
CV125	---	Programming to *1* will restore some CV's to factory settings	---	0

SPEED TABLE CV67-CV94 FOR 28 SPEED STEPS

When CV29's bit 4 is set to "1" it will use the speed table formed by CV67-CV94 to control speed (motor voltage). It allows you to setup each speed for all 28 speed steps. First, program CV29 to 18 for short addresses (1-127) or program CV29 to 50 for long addresses (128-9999) to enable speed table control. Then select throttle to 28 speed steps and run your loco at speed step 1. Use program CV on the main to change CV67's value (1-255) to adjust step 1's speed. The kick voltage, CV65 is only applied when the speed step changes from 0 to 1. You should switch between 0 to 1 many times to check step 1's speed. When done with CV67, select speed step 2 and program CV68. CV68's value must be greater than CV67's. When done with CV67-CV94, use read back CV to make sure their values are in increasing order.

Note: When using MRC Prodigy DCC to program addresses it will automatically disable the speed table (set CV29's bit 4 to "0"). Programming CV125 to 1 will also disable the speed table and re-program CV67-CV94 to a default linear speed setting.

TROUBLE SHOOTING

Whenever the decoder doesn't work please use the program track to program CV# 125 with value 1 to restore the decoder to factory settings. This should bring the decoder to life with address #3. This decoder should perform well with all DCC systems. The maximum DCC output should be less than 21 V. If the locomotive does not respond to commands, it may have lost its address. Please re-program the address and program CV19 to 0 (disable consist). If it responds to slowly, you should clear its momentum by reprogramming CV3 and CV4 to zero. If step 1's speed is too high, you should program start voltage, CV2 to zero. If its top speed is too slow, program top voltage CV5 to 31. You should also clean the track to improve electrical pickup. Read your DCC system manual to learn how to program and operate the decoder. For more information about registers/CVs and their functions, please refer to the NMRA DCC Standard & Recommended Practices, RP-9.2.2. This is available directly from the NMRA or their website at www.nmra.org.

FCC COMPLIANCE

This device complies with part 15 of the FCC Rules. Operation is subject to the following two conditions. (1) This device may not cause harmful interference, and (2) This device must accept any interference received, including interference that may cause undesired operation.

RETURN PROCEDURE

This decoder carries a 6 month warranty against factory defects. This warranty **does not** include abuse, misuse, neglect, improper installation, or any modifications made to this decoder, including but not limited to the removal of the NMRA plug if applicable. If it should become necessary to return the decoder for warranty repair/replacement, **please include a copy of the original sales receipt.** Please include a letter (printed clearly) with your name, address, daytime phone number, and a detailed description of the problem you are experiencing. Please also include a check or a money order for \$8.00 to cover return shipping and handling. If the decoder is no longer considered under warranty, then please include a check or a money order for \$29.00 to cover the cost of repair or replacement and return shipping and handling. **Be certain to return the decoder only.**

Any questions regarding Warranty Policy can be directed to our Customer Service Department by calling 732-225-6360 between the hours of 8:30am and 6:00pm EST, or by emailing: rtech@modelrectifier.com

Send the decoder to:

Model Rectifier Corporation
Attn: Parts & Service
80 Newfield Avenue
Edison, NJ 08837-3817 U.S.A

Printed in USA