

Micro-Mark®

340 Snyder Avenue, Berkeley Heights, NJ 07922

Tech Support 908-464-1094

www.micromark.com MMTechService@micromark.com

HOW TO MAKE A TWO PART MOLD

The pattern selected for casting may be a part from a kit, or a part you have built or modified yourself. If a complex part is used, such as a figure with an extended arm, it may need to be cast as two or more pieces. The mold is made from **ONE-to-ONE/RAPID** or **TEN-to-ONE** RTV (room temperature vulcanizing) Silicone Rubber. Read through the instructions below before beginning. Refer to the mixing directions included with each product.

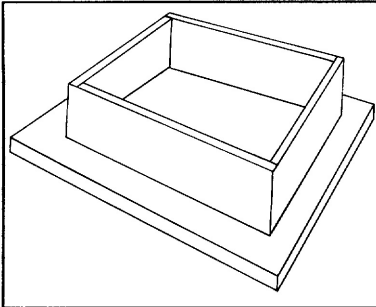

1. First build a mold box from wood, plastic* or heavy cardboard. Small pieces can even be cast within a "box" made of modeling clay. Build the mold box slightly larger than the pattern, allowing about 1/2" of space around the pattern on three sides and approximately 1" on the fourth side. Coat the inside of the box with RTV Mold Release.*

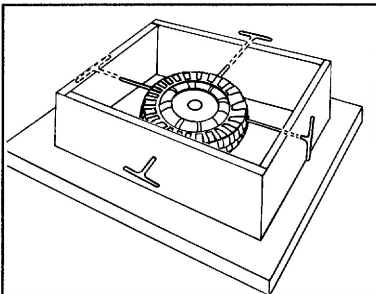

2. Punch or drill small holes in the pattern and sides of the mold box, about midline. Coat the pattern with mold release. Suspend the pattern in the mold box using T pins, heavy wire or small dowels. The pattern should be suspended in mid-air.

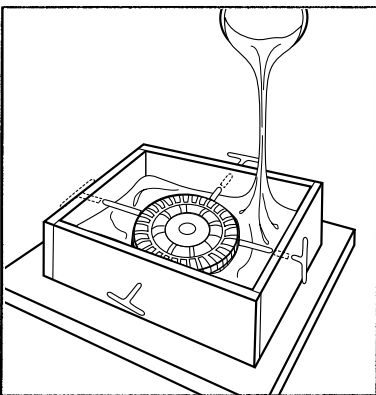

3. Follow the mixing instructions for the molding rubber, and mix enough material to surround the pattern up to its midline. Pour the rubber slowly into a corner of the box, allowing the rubber to flow freely around and under the pattern until it levels off at the midline of the pattern.

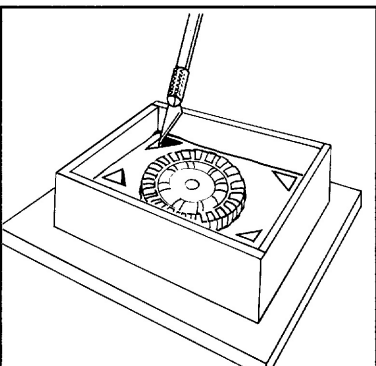

4. When the rubber has cured, use a sharp knife to form locking keys in each corner of the mold. A simple triangular wedge shape is fine. These keys will help to assure correct alignment of the two part mold when casting. Remove T pins and plug holes.

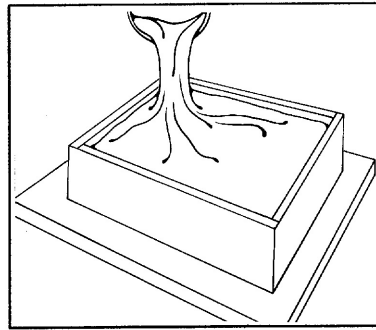

5. Next coat the mold with RTV Mold Release. Make sure mold release coats the inside of the locking keys also. The Mold Release will prevent the two mold halves from sticking to one another. Now mix enough of the Mold Rubber to complete the second half of the mold. Pour slowly as before and then allow rubber to cure.

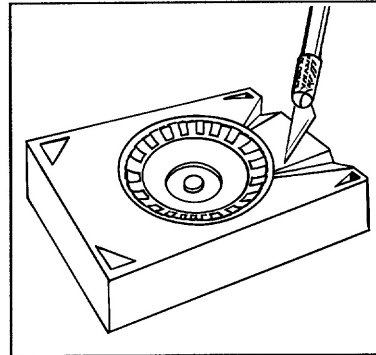

6. Separate the two mold pieces and remove the pattern. Now cut two wedge-shaped channels in the wider end of the mold. One of these sprue holes is for pouring the casting resin, and the other is a vent to allow the escape of displaced air while casting.

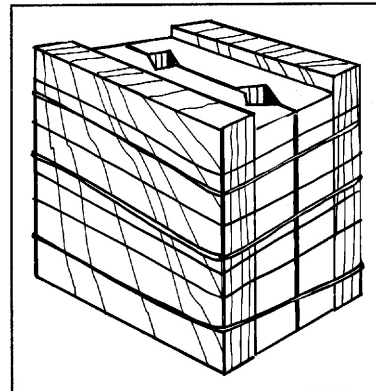

7. Place the two mold halves together between two pieces of wood. Use rubber bands to clamp the mold and wood securely.

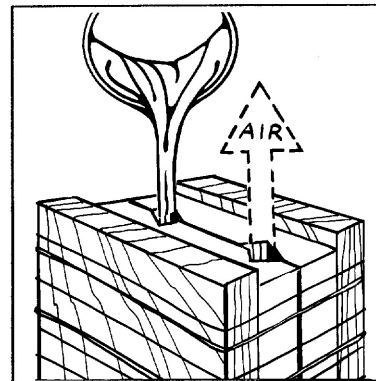

8. Mix the casting resin according to directions. Slowly pour the resin into a sprue hole. Fill up to the top of the sprue. Any remaining air bubbles will surface by gently squeezing the sides of the wood pieces.

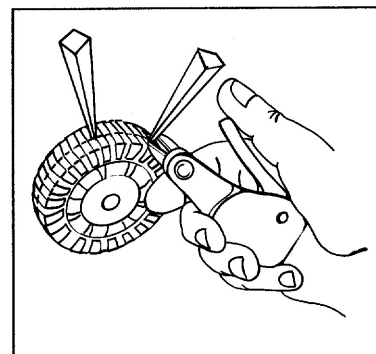

9. After the resin in the sprue hole has cured, separate the mold and remove the casting. Cut off the sprues close to the cast piece. If there are any surface blemishes, they can easily be removed by sanding.

* Be sure the plastic or pattern selected is compatible with the mold release.