

## INSTRUCTIONS FOR #80996 DADO WASHER SET

### FOR USE ON THE MICROLUX TILT ARBOR TABLE SAW WITH STANDARD BLADE ONLY

These special washers are tapered. When installed behind the blade, the blade will wobble as it rotates and cut a wide groove, called a dado. Select a washer from the chart below:

<u>DADO WIDTH</u>	<u>WASHER NUMBER</u>
1/16"	2
3/32"	3
1/8"	4
3/16"	5

To install the washer, first remove the blade guard from the machine. It will not be used during dado cutting, so ***extreme caution must be exercised when performing these cutting operations.*** Be sure to reinstall the guard when standard cutting operations are later resumed.

Next, following the instructions in the saw manual, remove the blade. Install the dado washer you selected on the mandrel, then reinstall the blade (see illustration below).

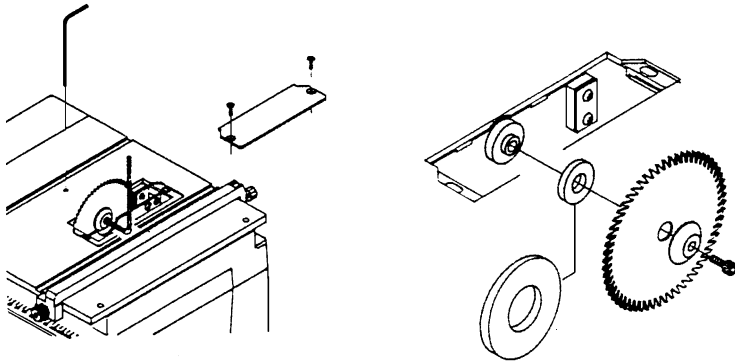

Reinstall and adjust the blade plate to clear the blade as it wobbles. The height of the blade can be adjusted for the proper dado depth. Turn on the saw and feed the workpiece slowly and smoothly into the blade. Use a push stick to protect your hands. For deep dados, make several light passes, readjusting the blade depth with each pass until the desired depth is achieved.

**Micro-Mark**<sup>®</sup> 340 Snyder Avenue  
Berkeley Heights, NJ 07922

Tech Support: 908-464-1094

[www.micromark.com](http://www.micromark.com) [MMTechService@micromark.com](mailto:MMTechService@micromark.com)